

Saturn HP Led (220/240V)

last update 13/11/2019

BEL1140

code 8029B. _ 0 _ _ _	6,5W - 220/240V - CE - IP65 - IK10
code 8029B. _ 1 _ _ _	9,5W - 220/240V - CE - IP65 - IK10
code 8029B. _ 2 _ _ _	16,5W - 220/240V - CE - IP65 - IK10
code 8029B. _ 3 _ _ _	24,0W - 220/240V - CE - IP65 - IK10

6.5W
9.5W



16.5W
24.0W

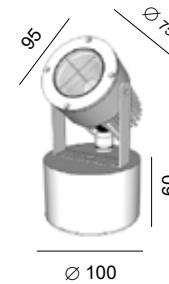

BEL LIGHTING srl
Avenue Ernest Solvay 42
B-1480 Saintes (Tubize)
Belgium
Phone: +32(0)2 3552428
Fax: +32(0)2 3550396
e-mail: info@bel-lighting.com
www.bel-lighting.com

ATTENTION - WARNING

Le luminaire doit être installé et connecté par un technicien qualifié.
The luminaire should be installed and connected by a qualified technician.

ACCESSORY SET (C)

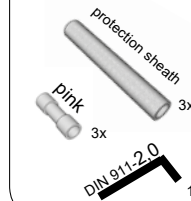

PART A

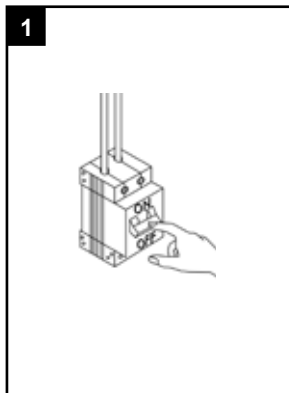

INSTALLATION INSTRUCTIONS - PART A

1. Before accessing any parts carrying live voltage, the power must be disconnected
Avant tout accès à des parties sous tension, la tension doit être coupée
2. Place the base of luminaire
Placer la base du luminaire
3. Make the electrical connection
Faire la connexion électrique
4. Assemble and close the luminaire
Assembler et fermer le luminaire
5. Switch on
Allumer

IP65

Volledig stofdicht - Beschermd tegen waterstralen uit alle richtingen
Étanche aux poussières - Protégé contre les jets d'eau de toutes directions
Staubdicht - Schutz vor Strahlwasser
Fully tight - Protected against water jets
Απόλυτη προστασία από τη σκόνη - Προστασία από πίεση νερού από όλες τις κατευθύνσεις



Correcte verwijdering van dit product (Elektrische&elektronische afvalapparatuur)
Comment éliminer ce produit (Déchets d'équipements électriques&électroniques)
Korrekte Entsorgung dieses Produkts (Elektronüll)
Correct disposal of this product (Waste electrical&electronical equipment)

2 GROUND FIXATION - DIMENSION HOLES

3x holes \varnothing 6.5mm at 120°
distance = 28mm from the center

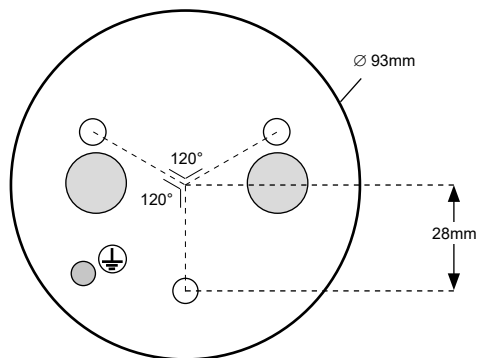

2x cable gland for cable diameter maximum 9mm

3 ELECTRICAL CONNECTION

NL - Voeg de voedingskabel in de beschermingskoker (A)
FR - Insérer le câble d'alimentation dans la gaine de protection(A).
EN - Insert the feeder in the protection sheath (A)
DE - Das Kabel in die Schutzhülle einfügen (A)
ΕΛ - Παρεμβάλετε τον τροφοδοτη στη θηκη προστασιας(A)

on 220/240V

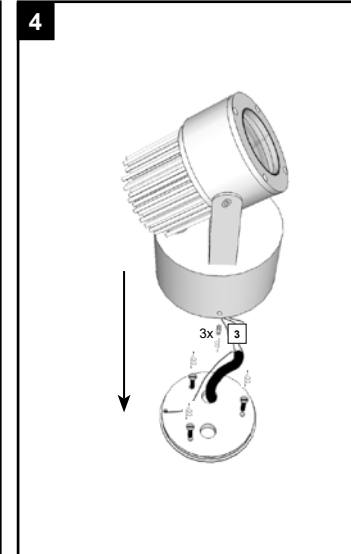
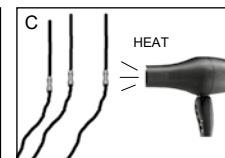
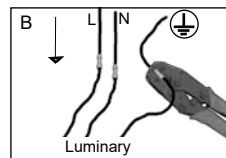
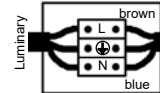

WAARSCHUWING
AVERTISSEMENT
WARNING
WARNING
ΠΡΟΣΟΧΗ

Lees de algemene gebruiksvoorwaarden : PART B
Lire attentivement les conditions générales d'utilisation: PART B
Read attentively the general instructions: PART B
Lesen Sie die allgemeinen Gebrauchsanweisungen: PART B
Διαβάστε τις γενικές οδηγίες : PART B