

Sampa PRO

last update 18/10/2021

BEL1184

Sampa PRO : code 8037P_ Led 6,5W or 9,5W or 15W - 220-240V AC /50-60Hz



Sampa PRO+ : code 8037D_ Led 6,5W or 9,5W or 15W - 220-240V AC /50-60Hz



BEL LIGHTING sprl
Avenue Ernest Solvay 42
B-1480 Saintes (Tubize)
Belgium
Phone: +32(0)2 3552428
Fax: +32(0)2 3550396
e-mail: info@bel-lighting.com
www.bel-lighting.com

WARNING - ATTENTION

The luminaire should be installed and connected by a qualified technician.
Le luminaire doit être installé et connecté par un technicien qualifié

INSTALLATION INSTRUCTIONS - PART A

1. Before accessing any parts carrying live voltage, the power must be disconnected
Avant tout accès à des parties sous tension, la tension doit être coupée
2. Preparation of troughs
Préparation du trou
3. Make the electrical connection
Faire la connexion électrique
4. Place the luminaire
Placer le luminaire
5. Switch on
Allumer

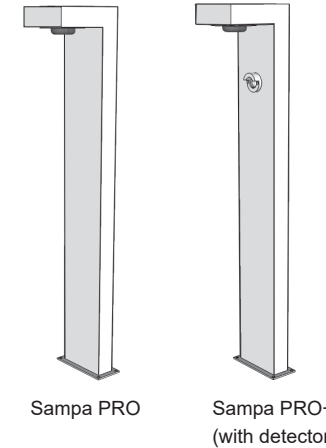
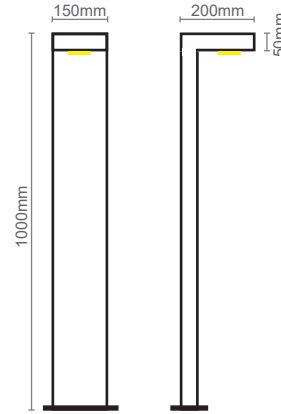

PART A

Lees de algemene gebruiksvoorwaarden : PART B
Lire attentivement les conditions générales d'utilisation: PART B
Read attentively the general instructions: PART B
Lesen Sie die allgemeinen Gebrauchsanweisungen: PART B
Διαβάστε της γενικές οδηγίες : PART B

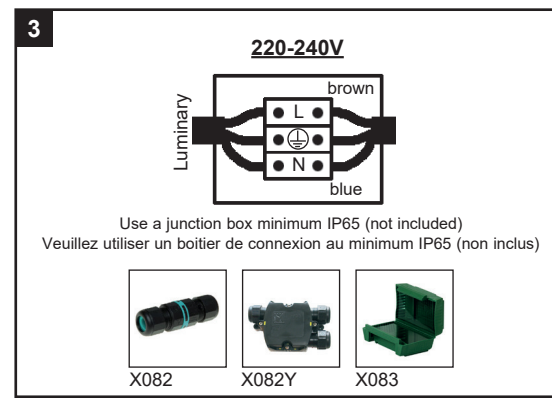
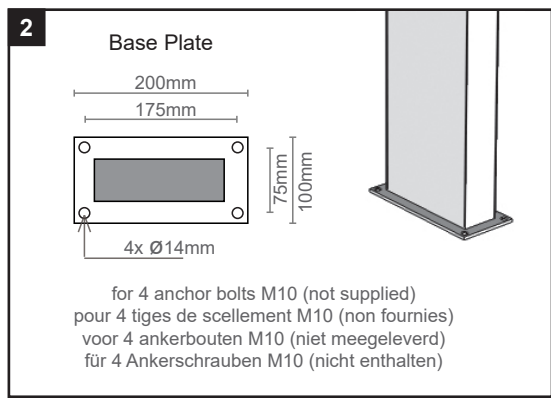
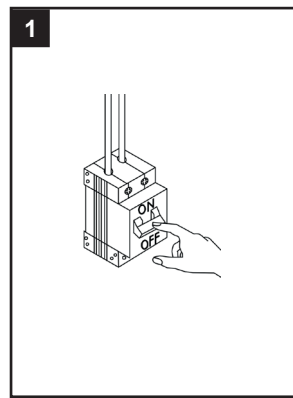

IP65 Volledig stofdicht- Beschermd tegen waterstralen uit alle richtingen
Etanche aux poussières - Protégé contre les jets d'eau de toutes directions
Staubdicht - Geschützt Gegen Strahlwasser
Fully tight against dust - Protected against water jets
Totalmente estanco al nuevo - Protegido contra chorros de agua
completamente a tenuta di polvere - Protetto contro i getti d'acqua

Correcte verwijdering van dit product (Elektrische&elektronische afvalapparatuur)
Comment éliminer ce produit (Déchets d'équipements électriques&electroniques)
Korrekte Entsorgung dieses Produkts (Elektromüll)
Correct disposal of this product (Waste electrical&electronic equipment)
Eliminación correcta de este producto (Material eléctrico y electrónico de descarte)
Corretto smaltimento del prodotto (Rifiuti elettrici ed elettronici)

WAARSCHUWING
AVERTISSEMENT
WARNING
WARNUNG
ΠΡΟΣΟΧΗ

Standard installation

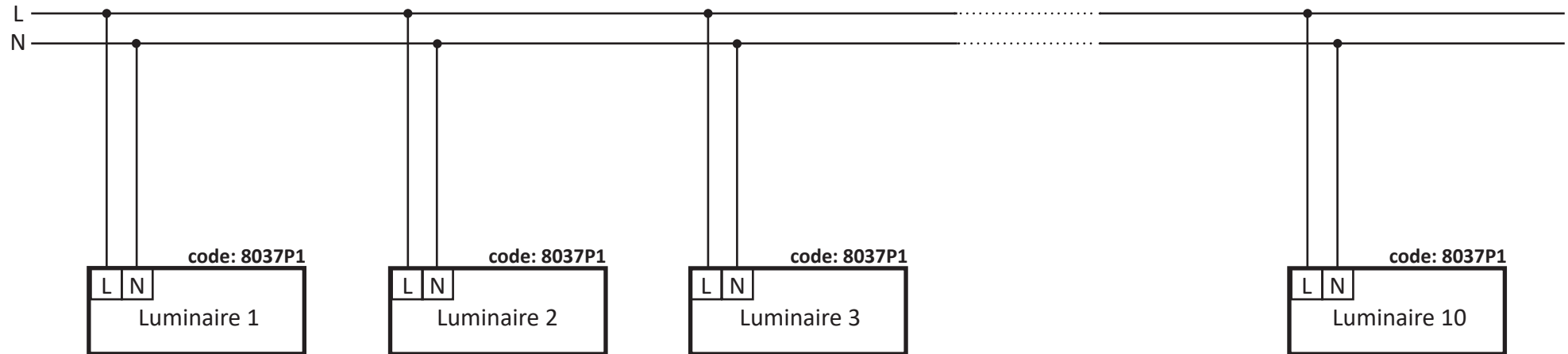

cable

GB	FR	DE	NL	IT	ES	PT	GR
L = brown N = blue	L = brun N = bleu	L = braun N = blau	L = bruin N = blauw	L = marrone N = blu	L = marron N = azul	L = castanho N = azul	L = καφέ N = μπλε

Standard installation

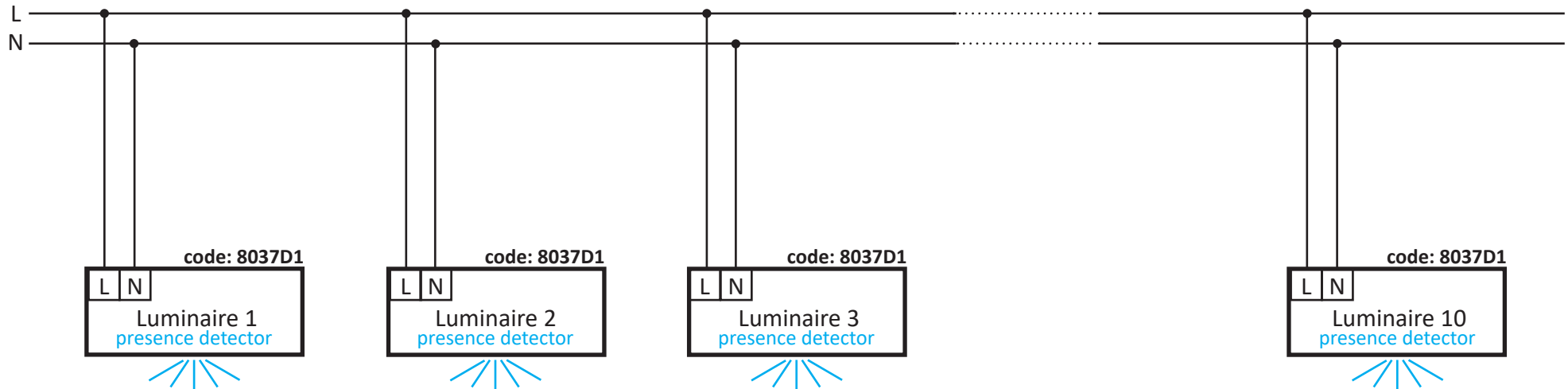

cable

GB	FR	DE	NL	IT	ES	PT	GR
L = brown N = blue	L = brun N = bleu	L = braun N = blau	L = bruin N = blauw	L = marrone N = blu	L = marron N = azul	L = castanho N = azul	L = καφέ N = μπλε

Presence detector (around 8m) with presetting:

- standby function with orientation lighting of 10%
- timer 5 minutes
- Twilight function at 200 lux
- Available on request: Remote control for a customized adjustment of the presence detector

Master / Slave connection: a maximum of 9 slave devices can be connected to the master device.

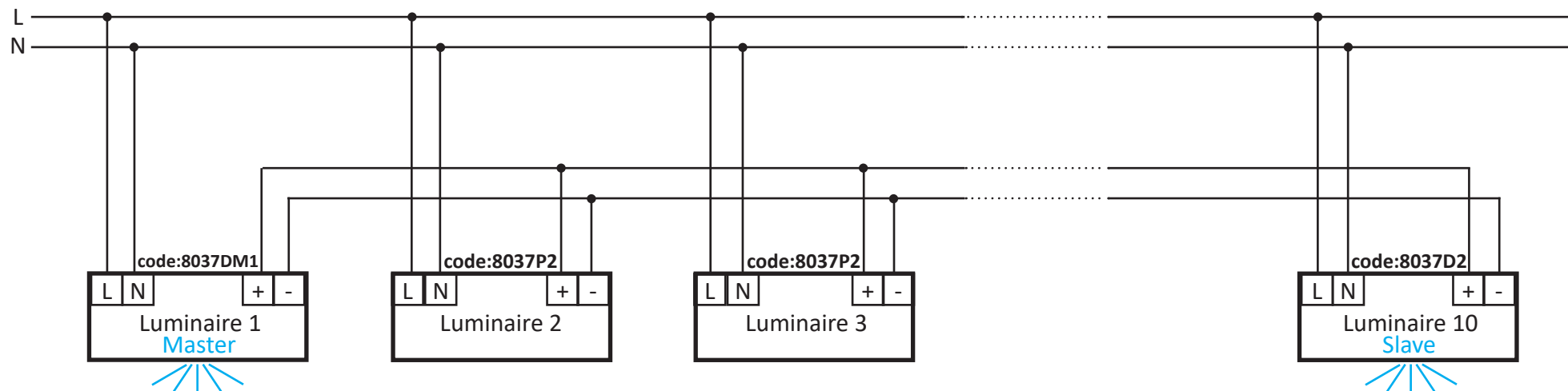

cable

GB	FR	DE	NL	IT	ES	PT	GR
<u>cable 3G 1mm²</u>	<u>câble 3G 1mm²</u>	<u>Kable 3G 1mm²</u>	<u>kable 3G 1mm²</u>	<u>cavo 3G 1mm²</u>	<u>cable 3G 1mm²</u>	<u>cabo 3G 1mm²</u>	<u>καλώδιο 3G 1mm²</u>
L = brown N = blue	L = brun N = bleu	L = braun N = blau	L = bruin N = blauw	L = marrone N = blu	L = marron N = azul	L = castanho N = azul	L = καφέ N = μπλε
<u>cable 2G 0,5mm²</u>	<u>câble 2G 0,5mm²</u>	<u>Kable 2G 0,5mm²</u>	<u>kable 2G 0,5mm²</u>	<u>cavo 2G 0,5mm²</u>	<u>cable 2G 0,5mm²</u>	<u>cabo 2G 0,5mm²</u>	<u>καλώδιο 2G 0,5mm²</u>
+ = red - = black	+ = rouge - = noir	+ = rot - = schwarz	+ = rood - = zwart	+ = rosso - = nero	+ = rojo - = negro	+ = vermelho - = preto	+ = κόκκινο - = μαύρο

Presence detector (around 8m) with presetting:

- standby function with orientation lighting of 10%
- timer 5 minutes
- Twilight function at 200 lux
- Available on request: Remote control for a customized adjustment of the presence detector

Standard installation

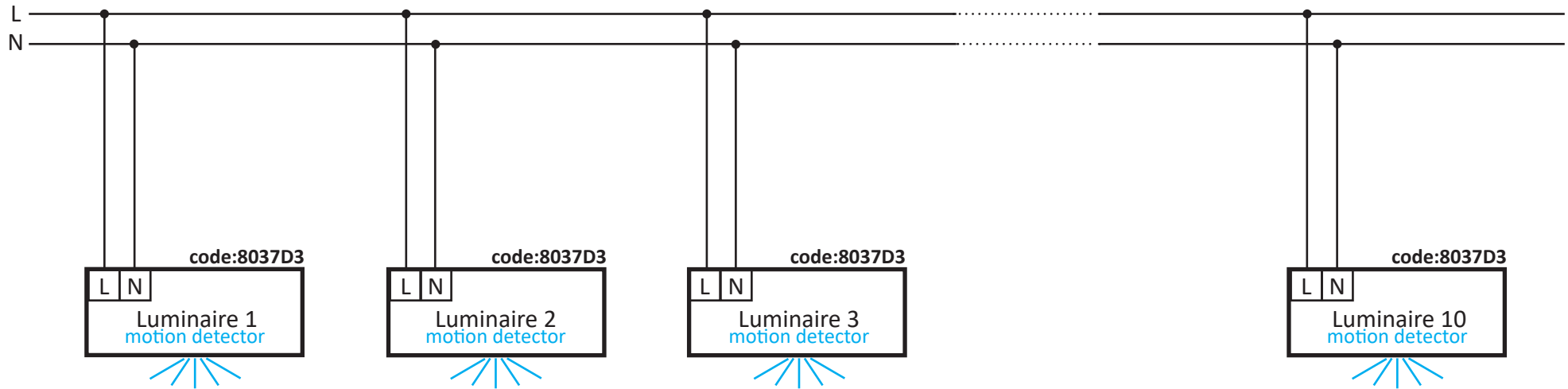

cable

GB	FR	DE	NL	IT	ES	PT	GR
L = brown N = blue	L = brun N = bleu	L = braun N = blau	L = bruin N = blauw	L = marrone N = blu	L = marron N = azul	L = castanho N = azul	L = καφέ N = μπλε

Motion detector with just an «on/off» function

Parallel connection: a maximum of 8 detector devices can be connected in parallel.

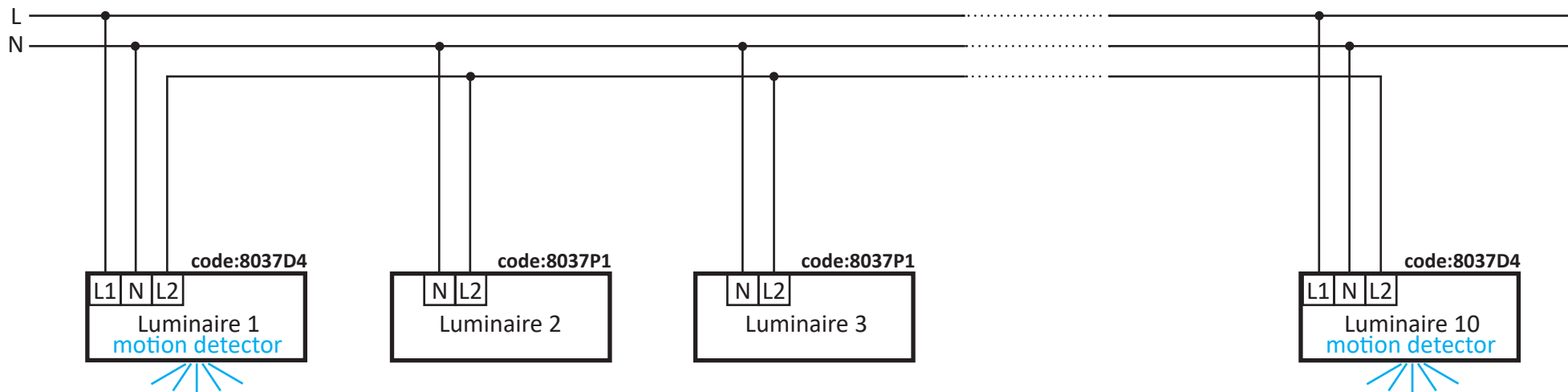

luminaires with detector

GB	FR	DE	NL	IT	ES	PT	GR
L1 = brown	L1 = brun	L1 = braun	L1 = bruin	L1 = marrone	L1 = marron	L1 = castanho	L1 = καφέ
N = blue	N = bleu	N = blau	N = blauw	N = blu	N = azul	N = azul	N = μπλε
L2 = grey	L2 = gris	L2 = grau	L2 = grijs	L2 = grigio	L2 = gris	L2 = cinzento	L2 = γκρι

Other luminaires (2, 3 , ...)

L2 = brown	L2 = brun	L2 = braun	L2 = bruin	L2 = marrone	L2 = marron	L2 = castanho	L2 = καφέ
N = blue	N = bleu	N = blau	N = blauw	N = blu	N = azul	N = azul	N = μπλε

Motion detector with just an «on/off» function