

Strato

last update 28/09/2015

BEL1163

Strato : code 8067.1_ _ _ _ 6,5W - 230V~ - CE - IP65 - IK09 -  -  - 

code 8067.2_ _ _ _ 6,5W - 230V~ - CE - IP65 - IK09 -  -  - 



BEL LIGHTING sprl
Avenue Ernest Solvay 42
B-1480 Saintes (Tubize)
Belgium
Phone: +32(0)2 3552428
Fax: +32(0)2 3550396
e-mail: info@bel-lighting.com
www.bel-lighting.com

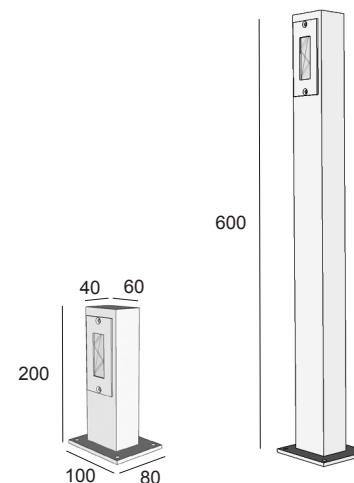

INSTALLATION INSTRUCTIONS - PART A

1. MAKE THE ELECTRICAL CONNECTION
2. PLACE THE LUMINARY
3. SWITCH ON

1 ELECTRICAL CONNECTION

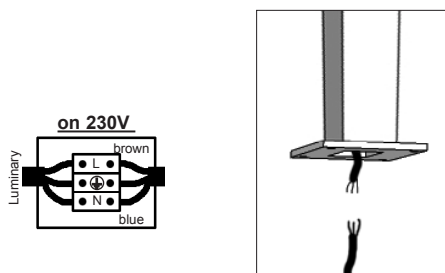

use a jonction box minimum IP65
(delivered separately)

use CONNEX 2 - Box IP68 - code X082

2 GROUND FIXATION - DIMENSION HOLES

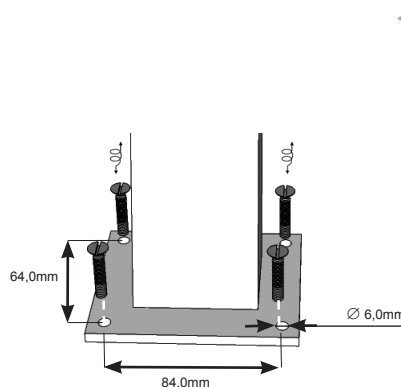

PART

A

Lees de algemene gebruiksvoorwaarden : PART B
Lire attentivement les conditions generales d'utilisation: PART B
Read attentively the general instructions: PART B
Lesen Sie die algemeinen Gebrauchsanweisungen: PART B
Διαβάστε της γενικές οδηγίες : PART B

WAARSCHUWING
AVERTISSEMENT
WARNING
WARNUNG
ΠΡΟΣΟΧΗ