



# Sampa D

last update 24/09/2015

BEL1131

**Sampa D :** code 8036.1\_37 . \_ \_ 6,5W - 230V - CE - IP65 - IK09 -  -  - 

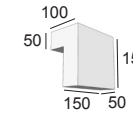

## INSTALLATION INSTRUCTIONS - PART A

1. DIMENSION HOLES
2. MAKE THE ELECTRICAL CONNECTION
3. PLACE THE LUMINARY ON THE WALL
4. SWITCH ON

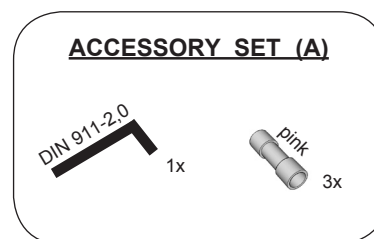
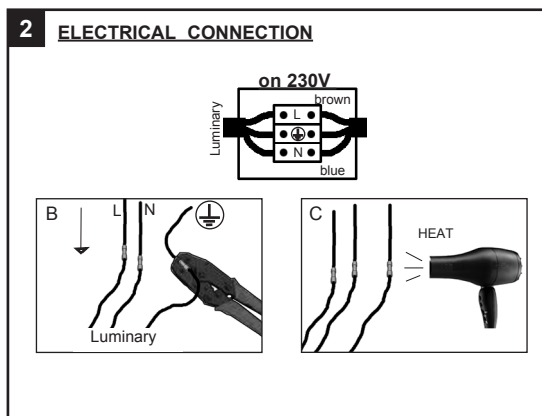
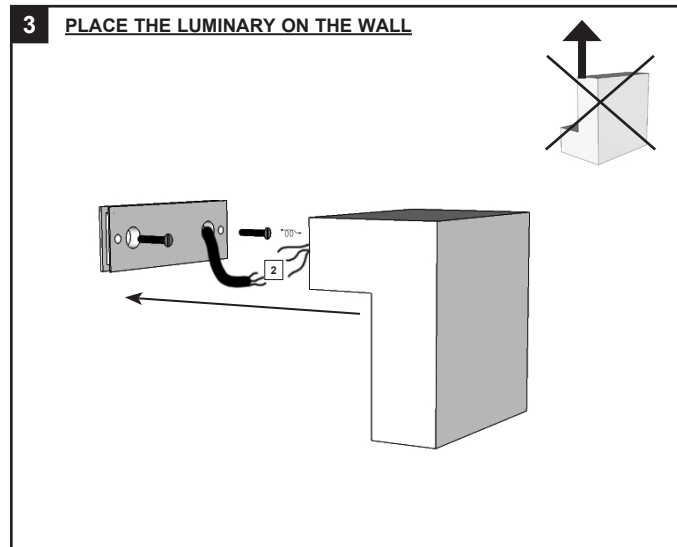
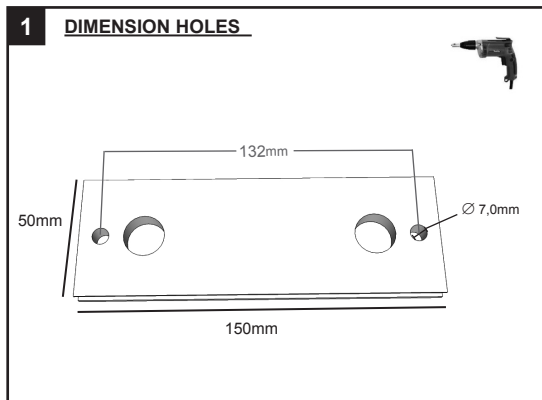

**BEL LIGHTING**

BEL LIGHTING sprl  
Avenue Ernest Solvay 42  
B-1480 Saintes (Tubize)  
Belgium  
Phone: +32(0)2 3552428  
Fax: +32(0)2 3550396  
e-mail: info@bel-lighting.com  
www.bel-lighting.com

**PART**

**A**

Lees de algemene gebruiksvoorwaarden : PART B  
Lire attentivement les conditions generales d'utilisation: PART B  
Read attentively the general instructions: PART B  
Lesen Sie die allgemeinen Gebrauchsanweisungen: PART B  
Διαβάστε της γενικές οδηγίες : PART B

WAARSCHUWING  
AVERTISSEMENT  
WARNING  
WARNUNG  
ΠΡΟΣΟΧΗ