

<b>Eco 1A :</b>	code 239221A . __	max.35W QPAR16/GU10 - 230V~ - CE - IP65 - IK09 - 
<b>Eco 1C :</b>	code 239221C . __	max.35W QPAR16/GU10 - 230V~ - CE - IP65 - IK09 - 
<b>Eco 2A :</b>	code 239A.GZ . __	max.35W QPAR16/GU10 - 230V~ - CE - IP65 - IK09 - 
<b>Eco 2C :</b>	code 239C.GZ . __	max.35W QPAR16/GU10 - 230V~ - CE - IP65 - IK09 - 

## INSTALLATION INSTRUCTIONS

1. FIT THE WALL FIXATION ON THE WALL
2. MAKE THE ELECTRICAL CONNECTION
3. PLACE THE LUMINARY
4. SWITCH ON

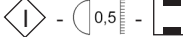
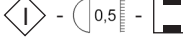
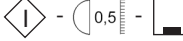
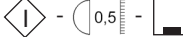
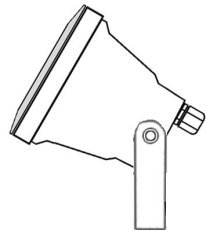

**2 ELECTRICAL CONNECTION**

NL - Voeg de voedingskabel in de beschermingskoker (A)  
FR - Insérer le câble d'alimentation dans la gaine de protection(A).  
EN - Insert the feeder in the protection sheath (A)  
DE - Das Kabel in die Schutzhülle einfügen (A)  
ΕΛ - Παρεμβάλετε τον τροφοδοτή στη θηκη προστασίας(A)

A



B



on 230V

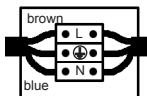

## ACCESSORY SET

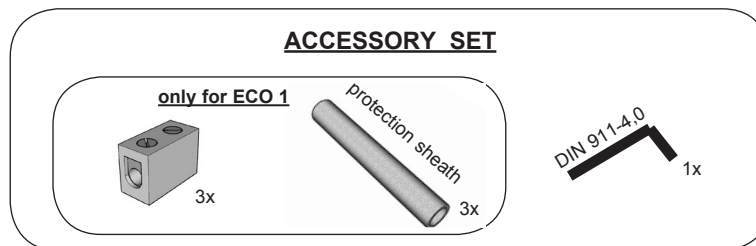

Option / Accessorie

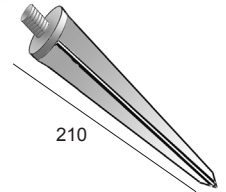

210

**ECOPIC**

805.00.00 

## belpasta 1g

- NL Voor een correcte installatie is het verplicht de schroeven te behandelen met belpasta.
- FR Pour une bonne installation, vous devez enduire les parties à visser avec la graisse belpasta ci-jointe.
- EN For a good installation, it is obliged to put the grease belpasta on the screwing part .
- DE Sie müssen die Teile der Leuchte, die geschraubt werden mit dem beigefügten Fett belpasta bestreichen.
- GR Για καλή εγκατάσταση, σας συνιστούμε να βάλετε στα σημεία προς βιδώμα λίγο γρasso belpasta, το οποίο βρίσκεται στην συσκευασία.

## PART

# A

Lees de algemene gebruiksvoorwaarden : PART B  
Lire attentivement les conditions générales d'utilisation: PART B  
Read attentively the general instructions: PART B  
Lesen Sie die allgemeinen Gebrauchsanweisungen: PART B  
Διαβάστε της γενικές οδηγίες : PART B

WAARSCHUWING  
AVERTISSEMENT  
WARNING  
WARNUNG  
ΠΡΟΣΟΧΗ